Anti-corrosion Intelligent Speed Dome Installation Manual

Version 1.0.0

Table of Contents

1	INSTALLATION PREPARATION	1
1.1	Basic requirements.....	1
1.2	Installation Check	1
1.3	Cable Requirements	1
1.3.1	Video Cable Requirements	1
1.3.2	Power Supply Cable Requirements	2
2	SPEED DOME INSTALLATION	3
2.1	Check Accessories.....	3
2.2	Open the Device	3
2.3	Dial Switch Setup.....	4
2.3.1	Dial Switch Address and Function.....	4
2.3.2	Dial Switch Setup.....	5
2.3.3	Address Setup	5
2.3.4	Baud Rate, Parity Setup, HD/SD Video Mode Setup	6
2.3.5	Terminal Matched Resistance Setup	7
2.4	SD Card Installation (Network Speed Dome).....	8
2.5	Speed Dome Installation	8
Note:	8
2.5.1	Cable Connection	8
2.5.2	Junction Box and Protection Tube Installation	10
2.5.3	Install Speed Dome	11
3	COMPONENT DIMENSION	14

3.1	Junction Box.....	14
3.2	Wall Mount Bracket.....	14
3.3	Corner Mount Bracket.....	15
3.4	Pole Mount Bracket.....	16
4	WALL MOUNT BRACKET INSTALLATION.....	18
4.1	Component Installation.....	18
4.2	Wall Mount Installation Steps.....	18
4.2.1	Installation Requirements.....	18
4.2.2	Installation Steps.....	18
5	CORNER MOUNT BRACKET INSTALLATION.....	20
5.1	Component Installation.....	20
5.2	Corner Mount Bracket Installation Steps.....	20
5.2.1	Installation Requirements.....	20
5.2.2	Installation Steps.....	20
6	POLE MOUNT BRACKET INSTALLATION.....	23
6.1	Component Installation.....	23
6.2	Pole Mount Bracket Installation Steps.....	23
6.2.1	Installation Requirements.....	23
6.2.2	Installation Steps.....	23
7	APPENDIX I LIGHTNING PROOF AND SURGE PROTECTION.....	26

8	APPENDIX II ABOUT RS485 BUS	27
8.1	RS485 Bus Main Feature	27
8.2	RS485 Bus Transmission Distance	27
8.3	The Problem in Practical Use	27
8.4	RS485 Bus FAQ	28
9	APPENDIX III THE RELATIONSHIP BETWEEN THE 24V AC CABLE DIAMETER AND THE TRANSMISSION DISTANCE.....	29
10	APPENDIX IV THE RELATIONSHIP BETWEEN THE 12V DC CABLE DIAMETER AND THE TRANSMISSION DISTANCE.....	31
11	APPENDIX IV WIRE GAUGE REFERENCE SHEET	33

Welcome

Thank you for purchasing our speed dome!

Please read the following safeguards and warnings carefully before you install or use the product!

Important Safeguards and Warnings

Safety Measures

1. Qualified Engineer Needed

- The installation engineer or maintenance engineer shall have corresponding CCTV system installation certificate or maintenance qualification certificate.
- The installation engineer or maintenance engineer shall have qualification certificate for work at height.
- The installation engineer or maintenance engineer shall have the basic knowledge and operation technique for low-voltage cable layout and low-voltage electronic cable connection.
- Please read the installation manual carefully and keep it well for future reference,
- We are not liable for any problems caused by unauthorized modifications or attempted repair.

2. Lifting Appliance Requirement

- Please select the proper speed dome installation mode and use the lifting appliances at the safety environment.
- The lifting appliances shall have the enough capacity to reach the installation height.
- The lifting appliances shall have safe performance.

The precaution measures include two types: Warning and Note.

- **Warning:** It is to alert you there is an optional risk of death or series injury!
- **Note:** It is to alert you there is an optional risk of damage or property loss!

Warning

1. All installation and operation here should conform to your local electrical safety codes. We assume no liability or responsibility for all the fires or electrical shock caused by improper handling or installation.
2. Be sure to use all the accessories (such as power adapter) recommended by manufacturer.
3. Laser light is dangerous; please do not look at it straight.
4. Do not connect several speed domes to one power adapter. It may result in overheat or fire if it exceeds the rated load.
5. Before you connect the cable, install or uninstall, or begin the daily maintenance work, please turn off the power and unplug the power cable.
6. Please make sure the produce is secure firmly on the wall or the ceiling.

-
7. Please turn off the power and unplug the power cable, If there is any smoke, disgusting smell, or noise. Please contact your local retailer or customer service center for help.
 8. All the examination and repair work should be done by the qualified service engineers. We are not liable for any problems caused by unauthorized modifications or attempted repair.

Note

1. Safety Transportation

- Heavy stress, violent vibration or water splash are not allowed during transportation, storage and installation.
- This series product must use split type package during the transportation.
- We are not liable for any damage or problem resulting from the integrated package during the transportation.

2. When device is malfunction

Shut down the device and disconnect the power cable immediately if there is smoke, abnormal smell or abnormal function. Please contact your local retailer ASAP.

3. Do not try to dismantle or modify the device

- There is risk of personal injury or device damage resulting from opening the shell.
- Please contact your local retailer if there is internal setup or maintenance requirement.
- We are not liable for any problems caused by unauthorized modifications or attempted repair.

4. Do not allow other object falling into the device

- Please make sure there is no metal or inflammable, explosive substance in the speed dome.
- The above mentioned objects in the device may result in fire, short-circuit or damage.
- Please shut down the device and disconnect the power cable if there is water or liquid falling into the camera. Please contact your local retailer ASAP.
- Please pay attention to the camera. Avoid the sea water or rain to erode the camera.

5. Handle carefully

Do not allow this series product fall down to the ground.

Avoid heavy vibration.

6. Installation Environment Requirement

- This series speed dome should be installed in a cool, dry place away from direct sunlight, inflammable, explosive substances and etc.
- This series product shall be away from the strong electromagnetism radiant, please keep it away from wireless power, TV transmitter, transformer and etc.

7. Daily Maintenance

-
- Please use the soft cloth to clean dust on the shell, or you can use soft cloth with cleaning liquid to clean the shell and then use soft cloth to make it dry.
 - Do not use gasoline, dope thinner or other chemical material to clean the shell. It may result in shell transfiguration or paint flake.
 - Do not allow the plastic or rubber material to touch the shell for a long time. It may result in paint flake.
 - It is highly recommended to use the product with a lightning-proof device, which can realize better lightning-proof effect.

1 Installation Preparation

1.1 Basic requirements

- All installation and operation here should conform to your local electrical safety codes.
- Before installation, please open the package and check all the components are included.
- Please make sure the speed dome installation environment and installation mode can meet your requirement. If there is special requirement, please contact your local retailer for more information.
- We assume no liability or responsibility for all the fires or electrical shock caused by improper handling or installation.

1.2 Installation Check

- Please make sure the installation environment has enough space to install the speed dome and its corresponding bracket.
- Please make sure the ceiling, wall and the bracket can sustain the 8X weight of the speed dome and its installation components.
- Please make sure the wall is thick enough to install expansion bolts (need to be purchased).
- Please notice that the installation height should be more than 6m if it is a laser speed dome.

1.3 Cable Requirements

1.3.1 Video Cable Requirements

The minimum video cable requirements are as follows:

- 75 ohm impedance.
- Full copper core cable.
- 95% knitted copper shield

Different types of devices use different cable models. Please refer to sheet 1-1 for the cable used by analog and network speed dome, please refer to sheet 1-2 for the cable used by HDCVI speed dome.

International Model	Max Distance (Ft\M)
RG59/U	750ft (229m)
RG6/U	1,000ft (305m)
RG11/U	1,500ft (457m)

Sheet 1-1

International Model	Max Distance (Ft\M)
SYV-75-3	720P (25fps\30fps) : 1640ft\500m
	720P (50fps\60fps) : 984ft\300m
	1080P (25fps\30fps) : 984ft\300m

Sheet 1-2

1.3.2 Power Supply Cable Requirements

Refer to appendix 3 for AC 24V power supply device.

Refer to appendix 4 for DC12V power supply device.

2 Speed Dome Installation

2.1 Check Accessories

Before the installation, please check the accessories one by one according to the packing list. Please make sure all the components are included (please refer to the packing list for more details).

2.2 Open the Device

Step 1

Please open the box and then take out the speed dome. See Figure 2-1.



Figure 2-1

Step 2

Use the screw to dismantle the bracket components, take out the filling material around the module, which is shown in Figure 2-2.

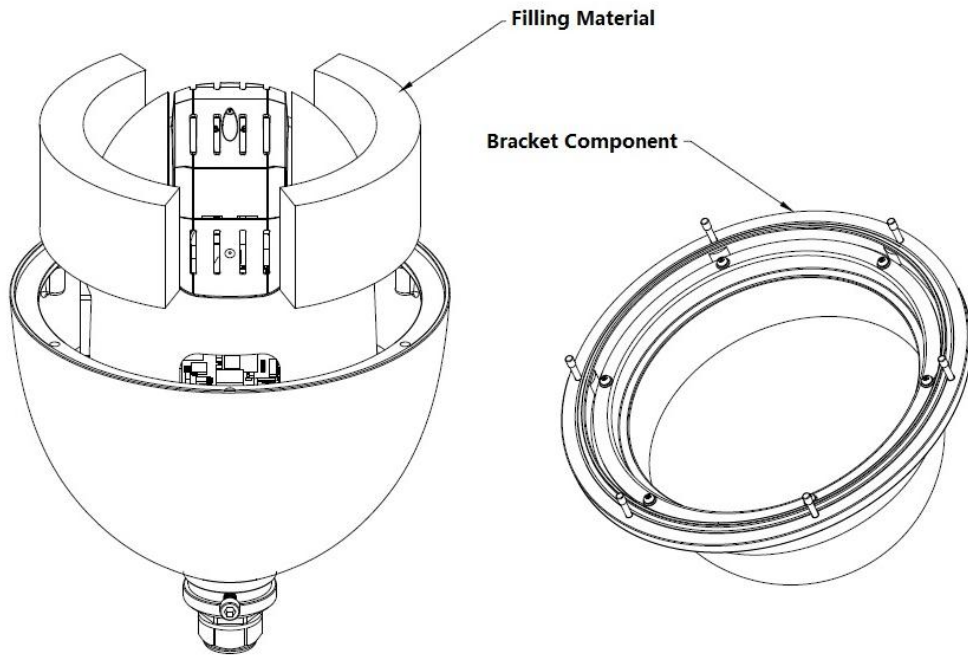

Figure 2-2

2.3 Dial Switch Setup

2.3.1 Dial Switch Address and Function

The corresponding functions of dial switch for both analog speed dome and HDCVI speed dome are different, which will be introduced respectively.

2.3.1.1 Analog Speed Dome

Dismantle the bracket component; you can see there are two dial switches on the PTZ mainboard. You can use them to set speed dome address, baud rate and parity. Please refer to Figure 2-3 for the dial switch address.

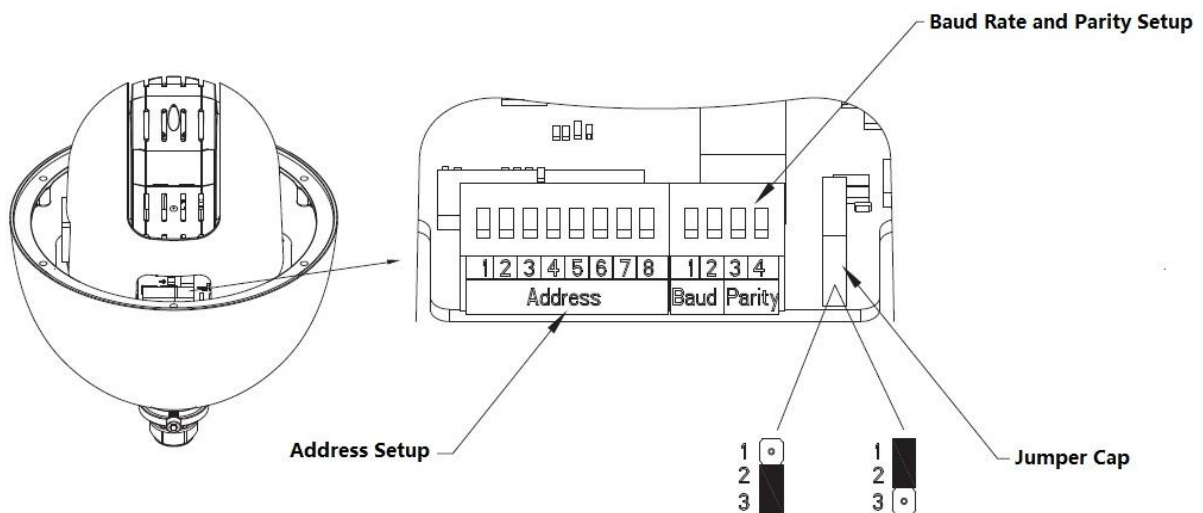

Figure 2-3

2.3.1.2 HDCVI Speed Dome

Dismantle the bracket component; you can see there are two dial switches on the PTZ mainboard. You can use them to set speed dome address, baud rate and HD/SD video mode. Please refer to Figure 2-4 for the dial switch address.

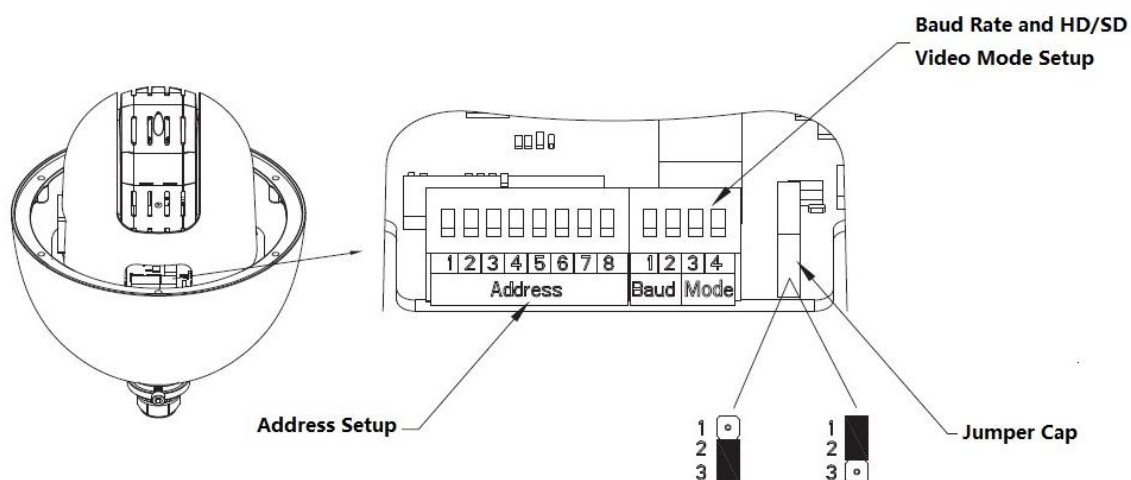

Figure 2-4

2.3.2 Dial Switch Setup

Users must set the address number, Baud rate, parity setup or HD/SD video mode which is used by the speed dome before controlling it. Only after all these settings are completed, can the speed dome respond to its control commands.

Note:

- Users need to install back the transparent cover component after taking out the EPE, setting the dial switch and drying the dust and impurity inside the device.
- It has to cut off the power and reboot the device after relevant information has been set again, which can make the new settings take effect.

There are two dial switch on the speed dome PTZ which are used to confirm the speed dome address, baud rate, parity or HD/SD vide mode. It is 1 when you set the button as ON. For address setup dial switch, 1 is the lowest bit, 8 is the highest bit; for the Baud rate, parity or HD/SD video mode setup dial switch, 1 is the lowest bit, 4 is the highest bit. (Intelligent speed dome self-adapt PELCO-D, PELCO-P, industrial standard protocol and control protocol which don't need to be set via dial switch).

2.3.3 Address Setup

The speed dome can adopt dial switch to set address, the encode mode adopts binary system. 1 to 8 is valid bit. The highest address bit is 255; see Figure 2-5 for address label and you can refer to the sheet 2-1 for address bit setup.

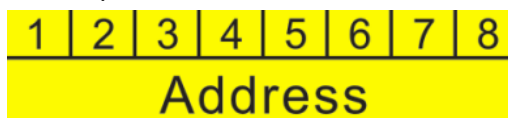

Figure 2-5

Address	1	2	3	4	5	6	7	8
---------	---	---	---	---	---	---	---	---

Address	1	2	3	4	5	6	7	8
0	OFF	OFF	OFF	OFF	OFF	OFF	OFF	OFF
1	ON	OFF	OFF	OFF	OFF	OFF	OFF	OFF
2	OFF	ON	OFF	OFF	OFF	OFF	OFF	OFF
3	ON	ON	OFF	OFF	OFF	OFF	OFF	OFF
4	OFF	OFF	ON	OFF	OFF	OFF	OFF	OFF
5	ON	OFF	ON	OFF	OFF	OFF	OFF	OFF
6	OFF	ON	ON	OFF	OFF	OFF	OFF	OFF
7	ON	ON	ON	OFF	OFF	OFF	OFF	OFF
8	OFF	OFF	OFF	ON	OFF	OFF	OFF	OFF
.....							
254	OFF	ON	ON	ON	ON	ON	ON	ON
255	ON	ON	ON	ON	ON	ON	ON	ON

Sheet 2-1

2.3.4 Baud Rate, Parity Setup, HD/SD Video Mode Setup

The functions which need to be set are different for analog speed dome and HDCVI speed dome, which will be introduced respectively.

2.3.4.1 Analog Speed Dome

It is used to set speed dome Baud rate and parity. 1 and 2 bits are used to set Baud rate while 3 and 4 bits are used to set parity, see Figure 2-6 for the labels of Baud rate and parity, see sheet 2-2 and 2-3 for settings of baud rate and parity.

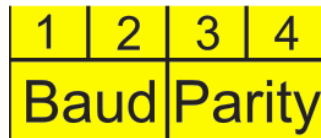

Figure 2-6

Please refer to the baud rate setup sheet 2-2 for detailed information.

1	2	Baud rate
OFF	OFF	9600bps
ON	OFF	4800bps
OFF	ON	2400bps
ON	ON	1200bps

Sheet 2-2

Please refer to the parity setup sheet 2-3 for detailed information.

3	4	Parity
OFF	OFF	NONE
ON	OFF	EVEN
OFF	ON	ODD
ON	ON	NONE

Sheet 2-3

2.3.4.2 HDCVI Speed Dome

It is to set the speed dome baud rate and HD/SD video mode. From 1 to 4 dial switch, 1 and 2 bit are Baud rate setup bit, 3 and 4 bit are HD/SD video mode setup bit. See Figure 2-7 for the labels of Baud rate and HD/SD video mode; refer to sheet 2-4 and 2-5 for the settings of Baud rate and HD/SD video mode.

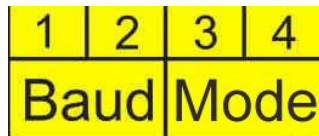

Figure 2-7

1	2	Baud rate
OFF	OFF	9600bps
ON	OFF	4800bps
OFF	ON	2400bps
ON	ON	1200bps

Sheet 2-4

3	4	HD/SD video mode
OFF	OFF	HD
ON	OFF	SD
OFF	ON	Self-adaptive
ON	ON	HD

Sheet 2-5

2.3.5 Terminal Matched Resistance Setup

The connection mode of device terminal 120Ω resistance is equipped on the power board. There are two connection modes which are shown in Figure 2-8.

	1~2	2~3
120Ω	ON	OFF

Figure 2-8

The factory default connection mode is shown in Figure 2-9; the jumper (connection board) is plugged into pin 2 and pin 3, which means 120Ω resistance is not connected to the device.

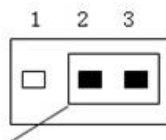

Factory Default Jump Setup
(120Ω Resistance Unconnected)

Figure 2-9

If you want to connect the 120Ω resistance, you have to pull the jumper out of pin 2 and pin 3, and connect to pin 1 and pin 2, then 120Ω resistance is connected to the circuit, see Figure 2-10.

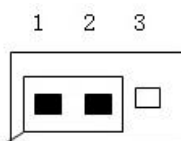

Jumper Setup
(120Ω Resistance Connected)

Figure 2-10

2.4 SD Card Installation (Network Speed Dome)

Dismantle the bracket component, open the window cover, then you can see there is a Micro-SD card slot on the module ISP board, which is shown in Figure 2-11. Micro-SD card is used to save the data.

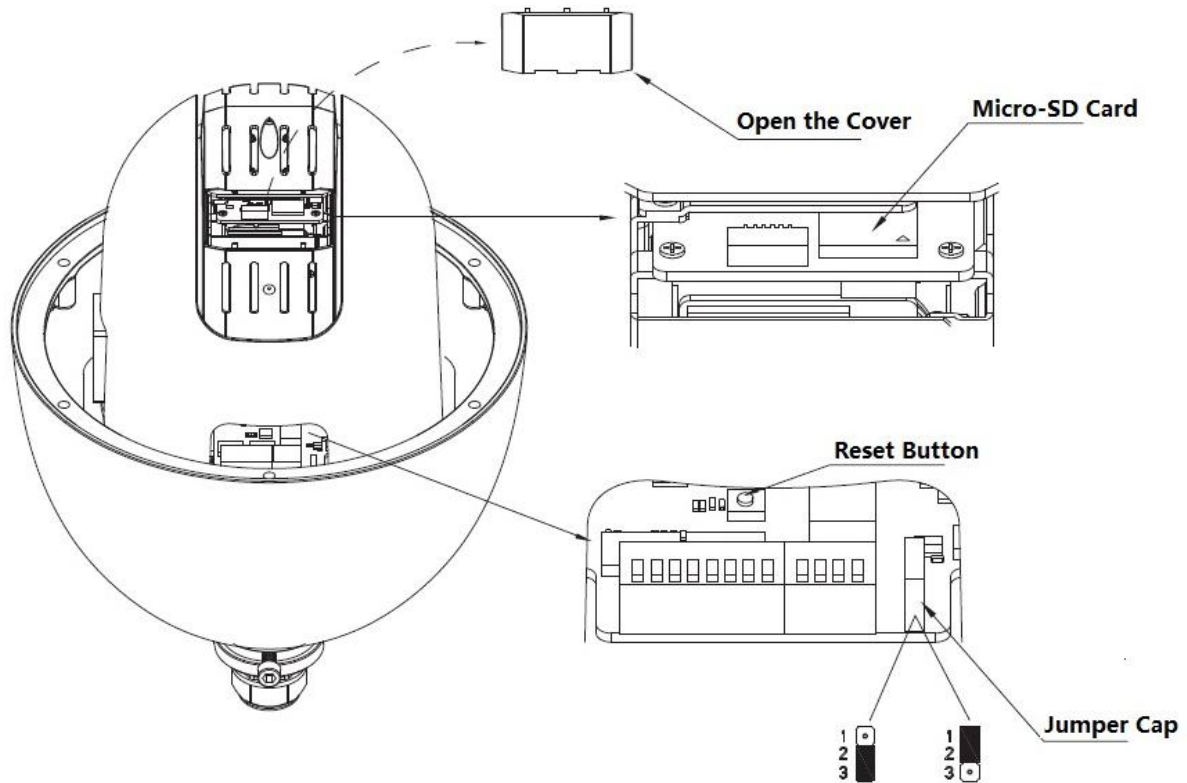

Figure 2-11

2.5 Speed Dome Installation

Note:

The installation chapter can be applied to analog speed dome and network speed dome etc. There are various types of brackets for speed dome to meet the application requirements of different environments. Please refer to chapter 3 to chapter 6 for more details about speed dome installation.

Here we are going to install the analog speed dome with the analog speed dome wall-mounted bracket.

2.5.1 Cable Connection

The speed dome is equipped with a multi-function combination cable, which includes power cable, video cable, audio cable, RS485 control cable, alarm cable, network cable, high-frequency cable, optical fiber and so on, which is shown in Figure 2-12.

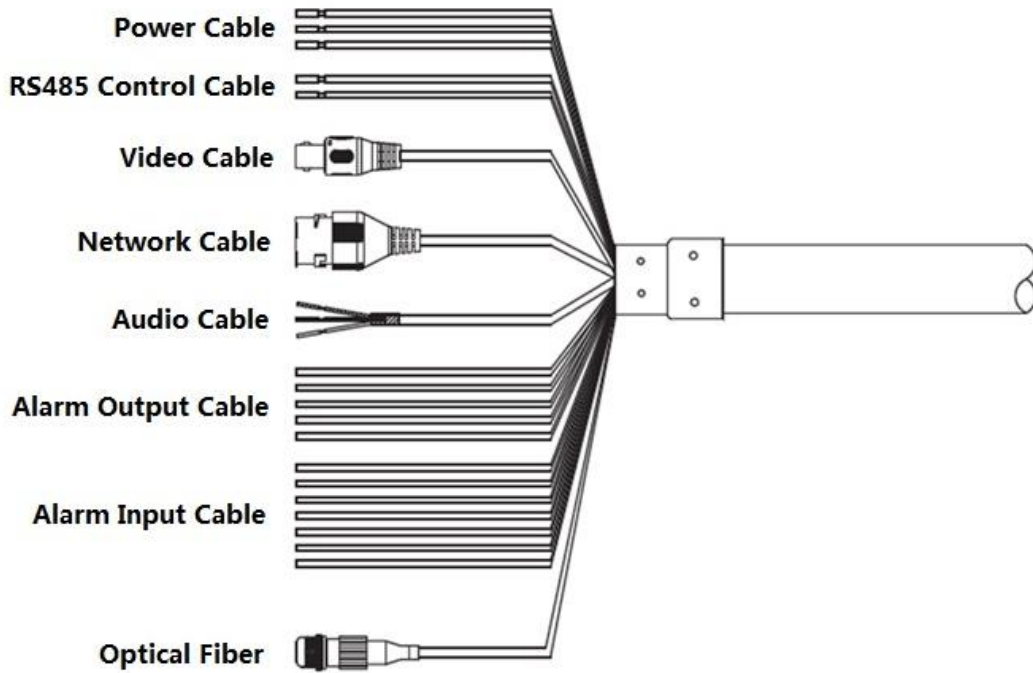

Figure 2-12

Note:

The figure above is for reference only, the combination cable is based on the model of speed dome.

Connect the safety hook of the speed dome to the quick installation connector, connect the integration cable reserved by the wall-mounted bracket to the multi-function combination cable of the speed dome according to the requirements, and then use the insulated rubber tape to twist the connection joints respectively to make it waterproof, which is shown in Figure 2-13.

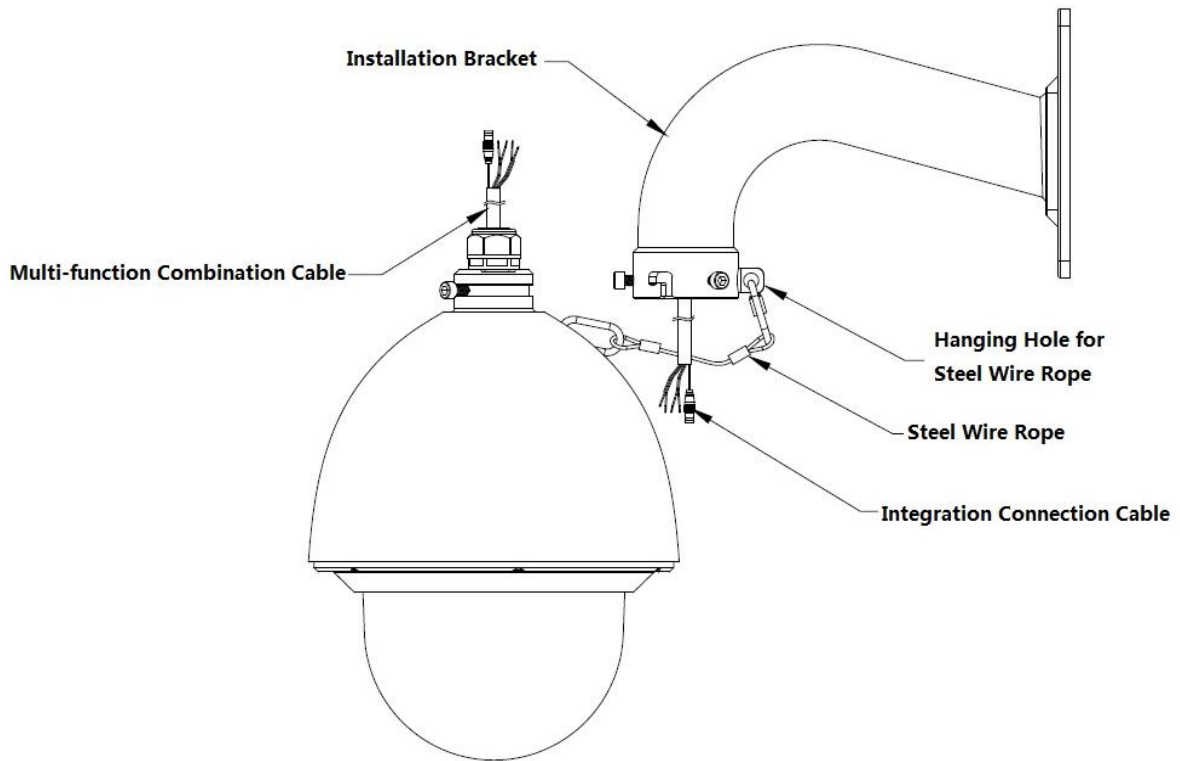

Figure 2-13

Note:

The video port is covered with a heat shrink tube of high shrinking ratio. It needs to heat and shrink the tubes on both sides after the video port is well connected, which is to make sure the video port is damp proof and waterproof.

2.5.2 Junction Box and Protection Tube Installation

The junction box is used to protect speed dome cable and port, avoid corrosion from external environment. The junction box consists of box body, seal ring and plug, which is shown in Figure 2-14.

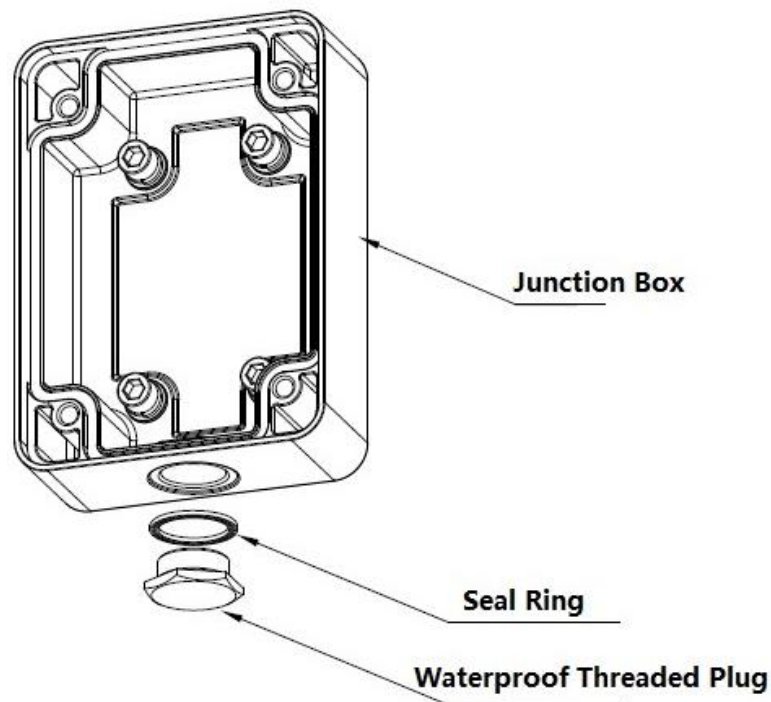

Figure 2-14

The junction box shall be used together with the protection tube, the installation steps are shown as follows:

Step 1

Use expansion bolts and screws to fix the junction box on the wall.

Step 2

Cover the cable with protection tube component in advance; take down the threaded connector and the plug and seal ring of the junction box, keep the seal ring of the junction box well for future use.

Step 3

Cover the seal ring on the threaded connector and then tighten both sides of the threaded connector with the thread of outlet hole and protection tube respectively, which is shown in Figure 2-15.

Note:

All the screws are used together with the seal ring included in the accessories bag.

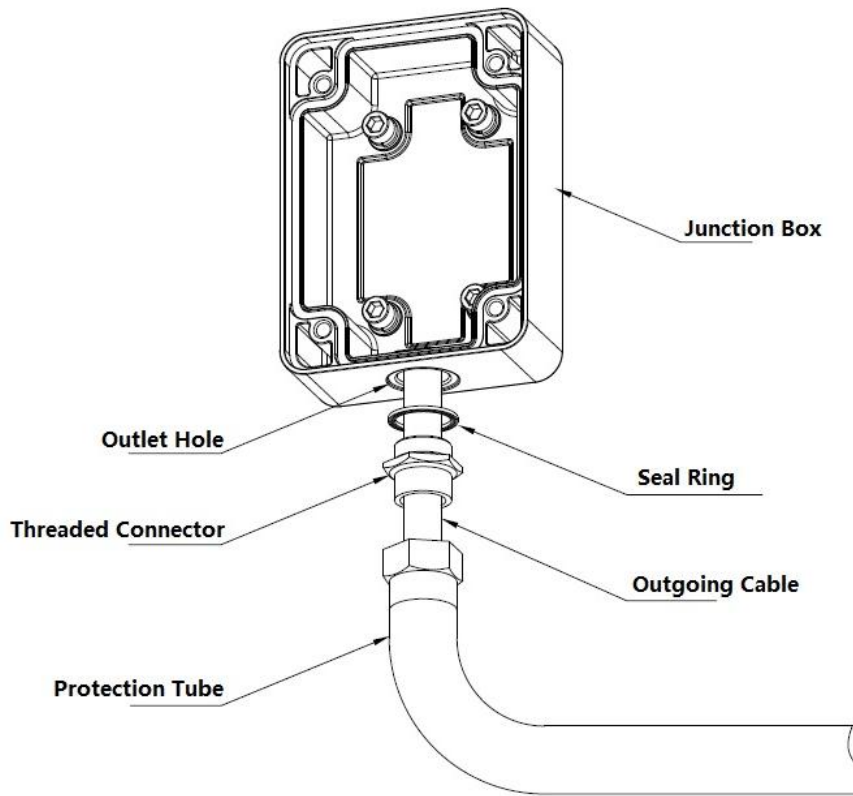

Figure 2-15

The installation result is shown in Figure 2-16.

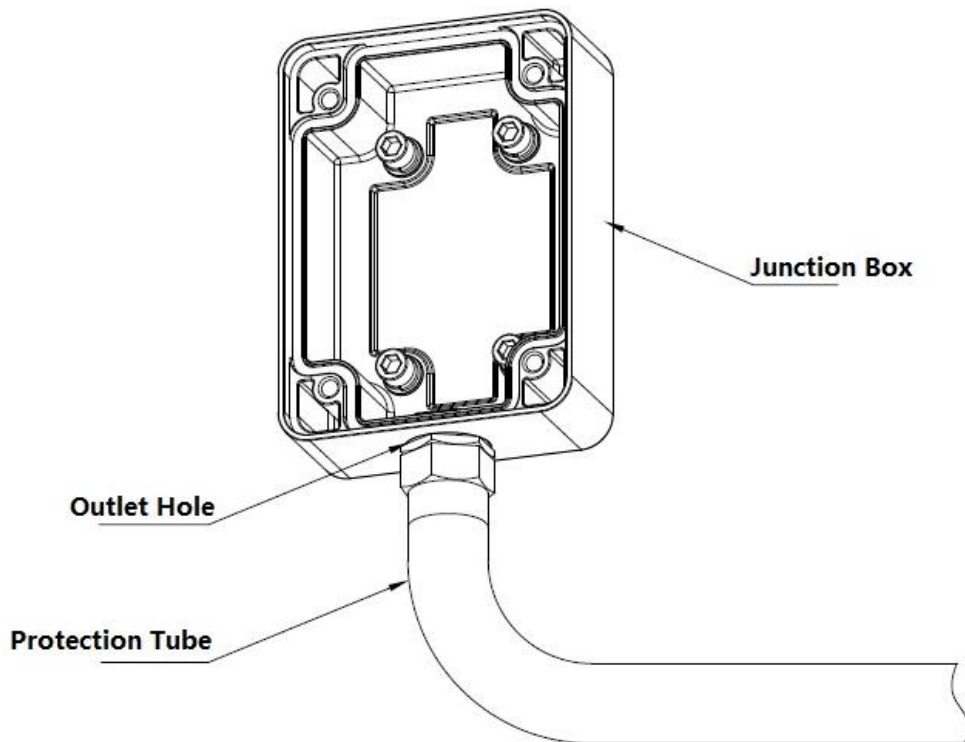

Figure 2-16

2.5.3 Install Speed Dome

Step 1

Slowly put the connected integration connection cable and multi-function combination cable into the wall-mounted bracket.

Step 2

Use the screws to fix the junction box on the bracket.

Step 3

Push the pre-hung screw of the speed dome flange along the hanging hook on the bracket till the screw reaches the bottom of the hanging hook.

Step 4

Rotate the speed dome to make the pre-hung screw stuck tightly with the hanging hook.

Step 5

Screw three M6*14 stainless screws on the bracket into the groove of the speed dome flange, use inner hex tool to fasten the three pre-hung stainless screws on the speed dome, which is shown in Figure 2-17.

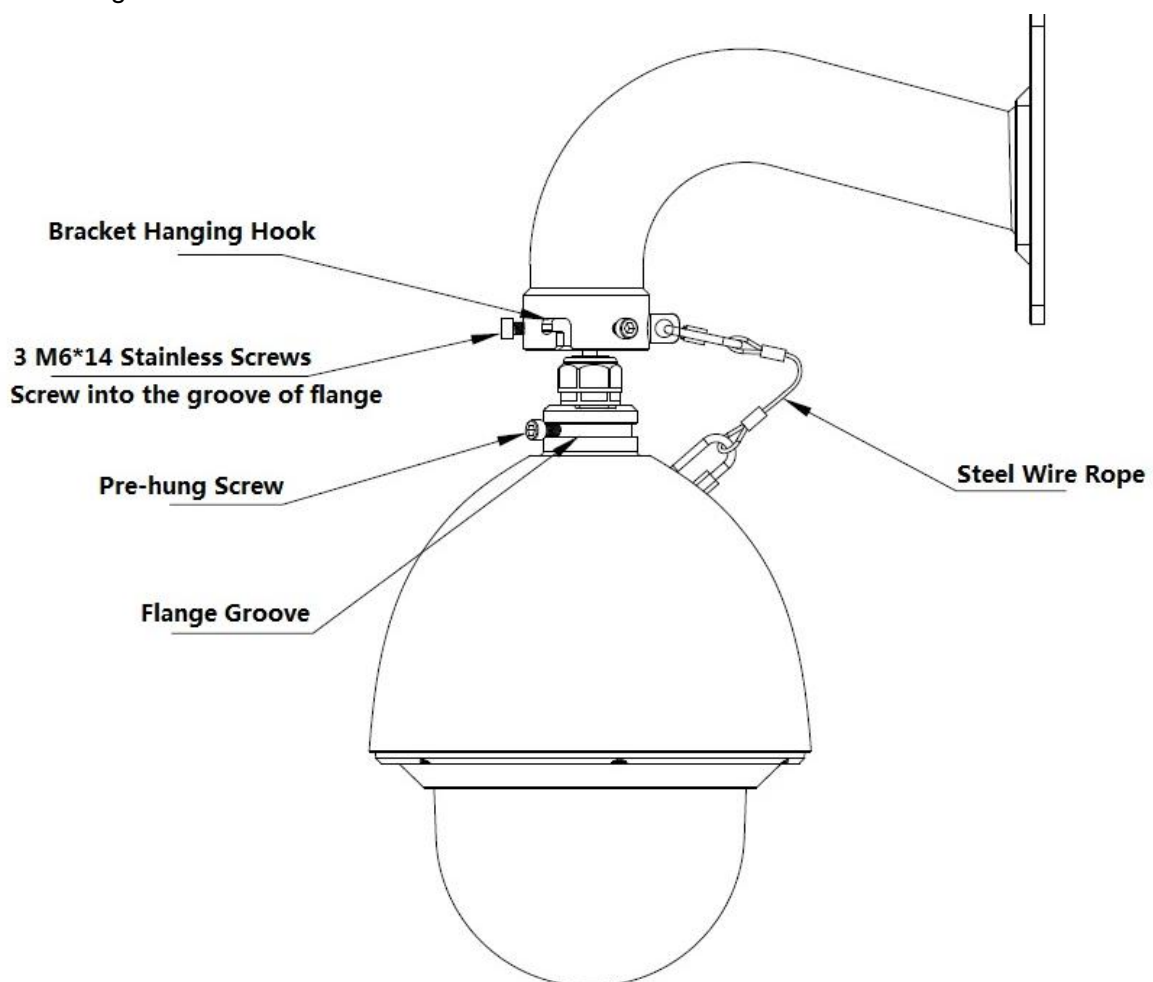

Figure 2-17

Step 6

Check if the three stainless screws on the quick installation connector are tightened well, make sure the speed dome is firmly fixed and reliable without being loose, besides, the safety hook is reliably connected. So far the installation of speed dome is completed, which is shown in Figure 2-18.

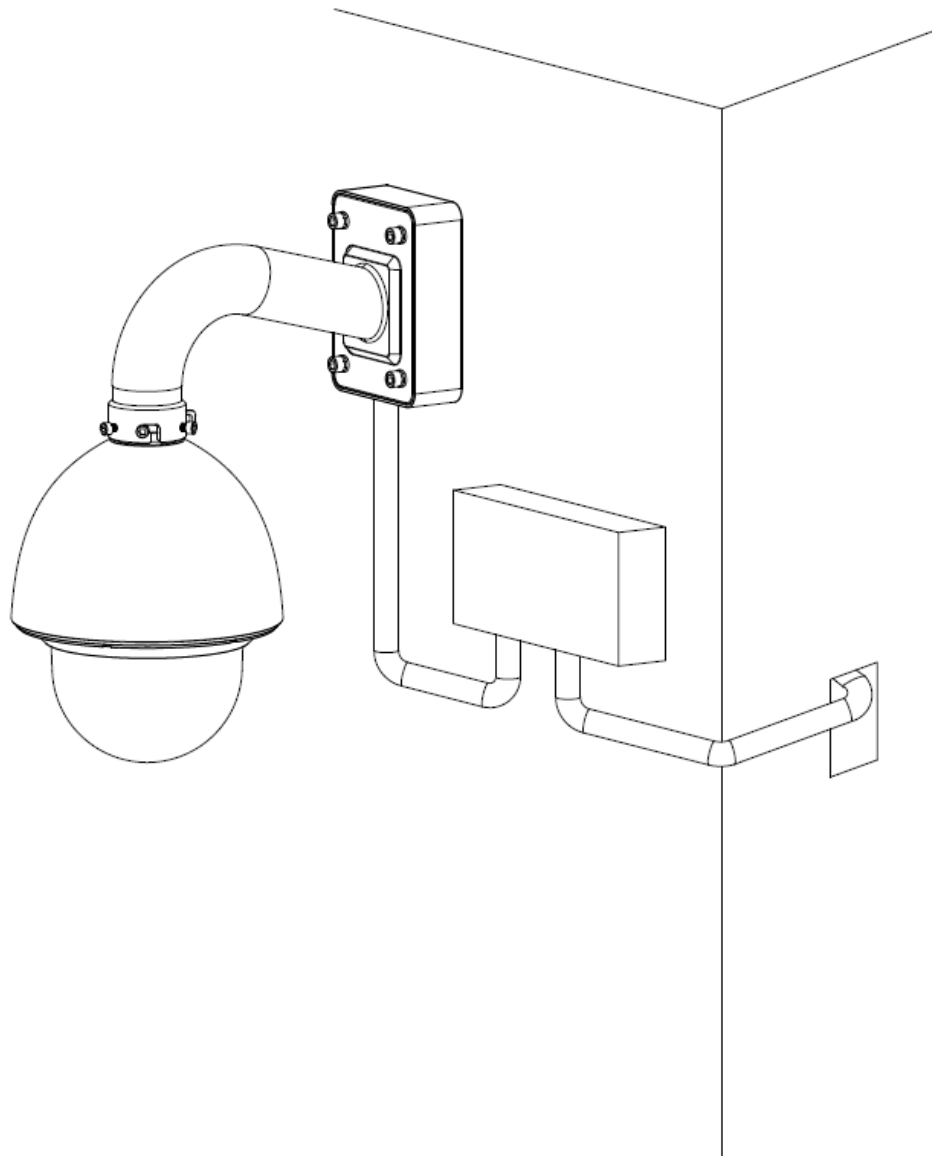

Figure 2-18

3 Component Dimension

3.1 Junction Box

Please refer to Figure 3-1 for the dimension of junction box.

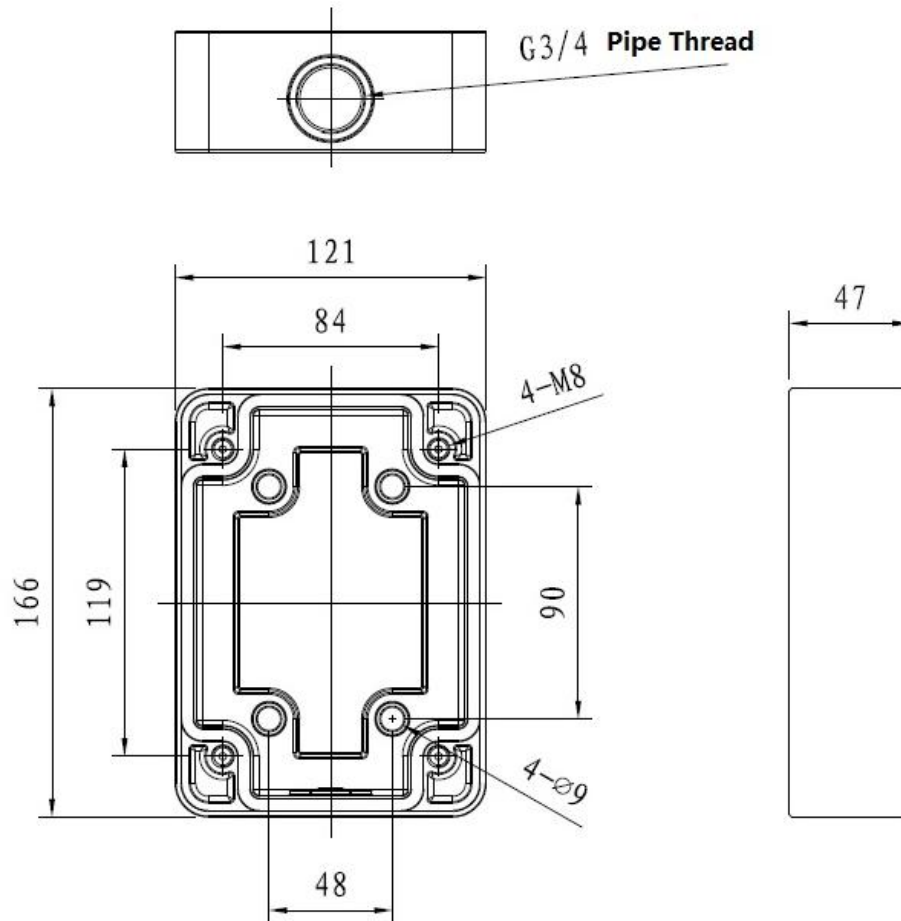

Figure 3-1

3.2 Wall Mount Bracket

Please refer to Figure 3-2 for the dimension of wall mount bracket.

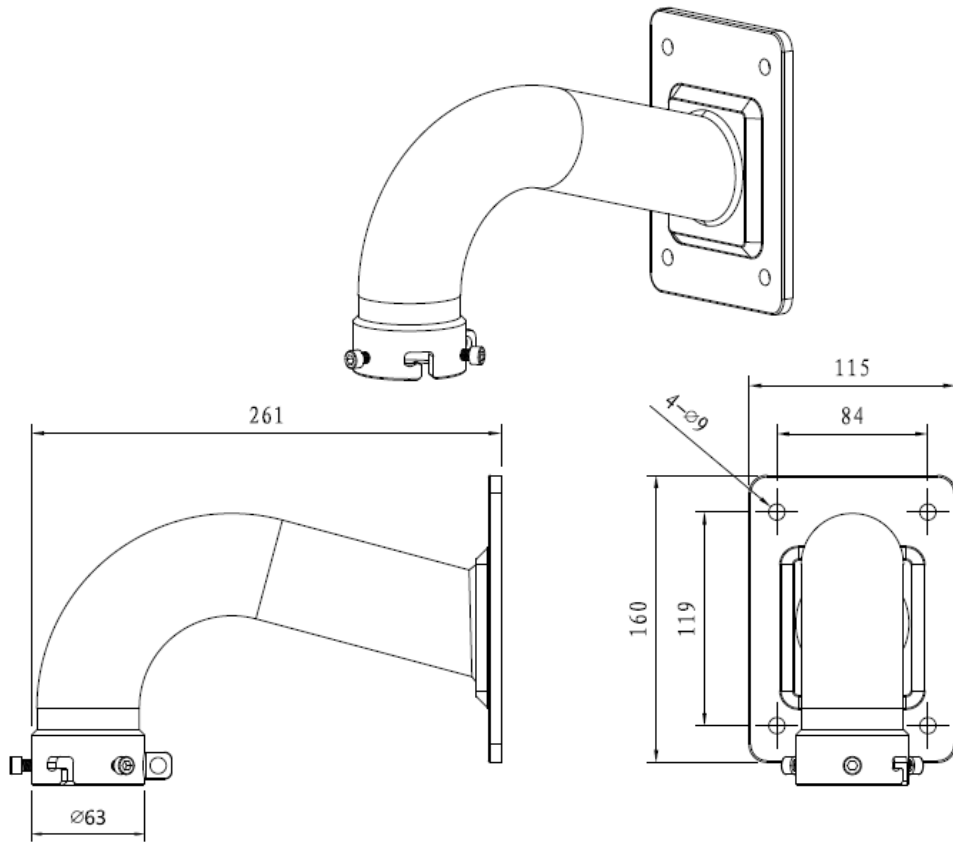

Figure 3-2

3.3 Corner Mount Bracket

Please refer to Figure 3-3 for the dimension of corner mount bracket.

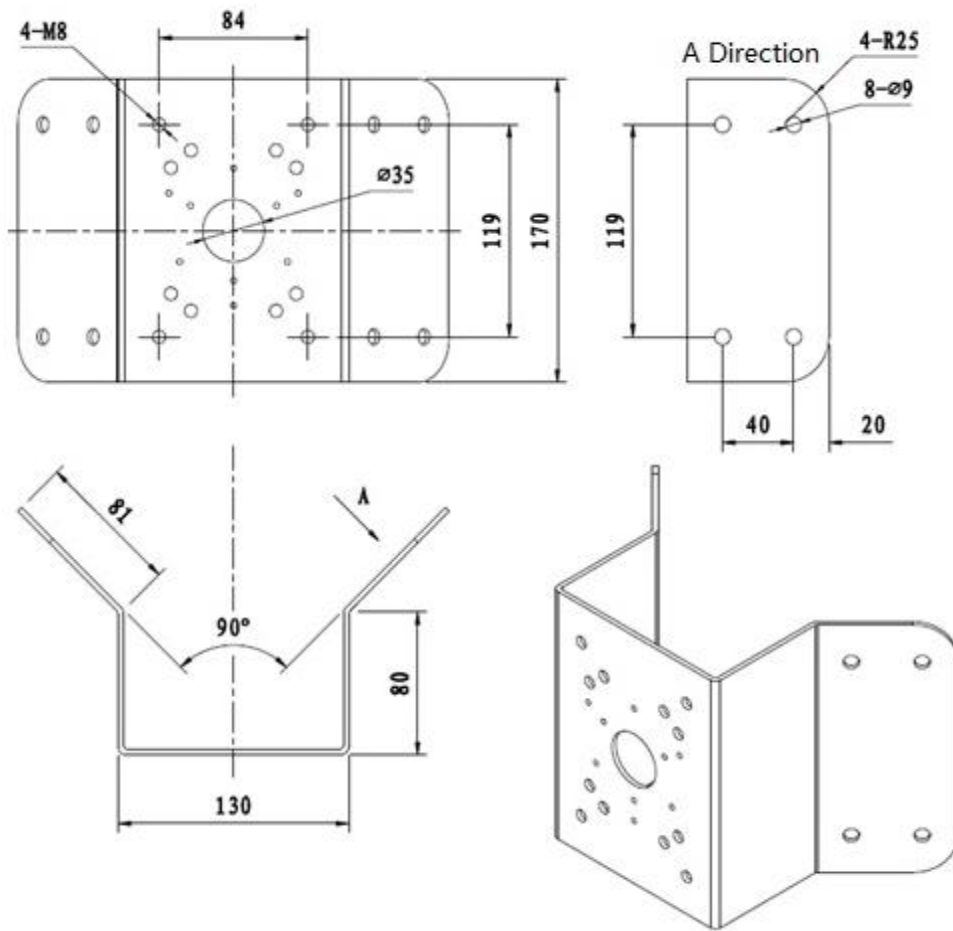

Figure 3-3

3.4 Pole Mount Bracket

Please refer to Figure 3-4 for the dimension of pole mount bracket.

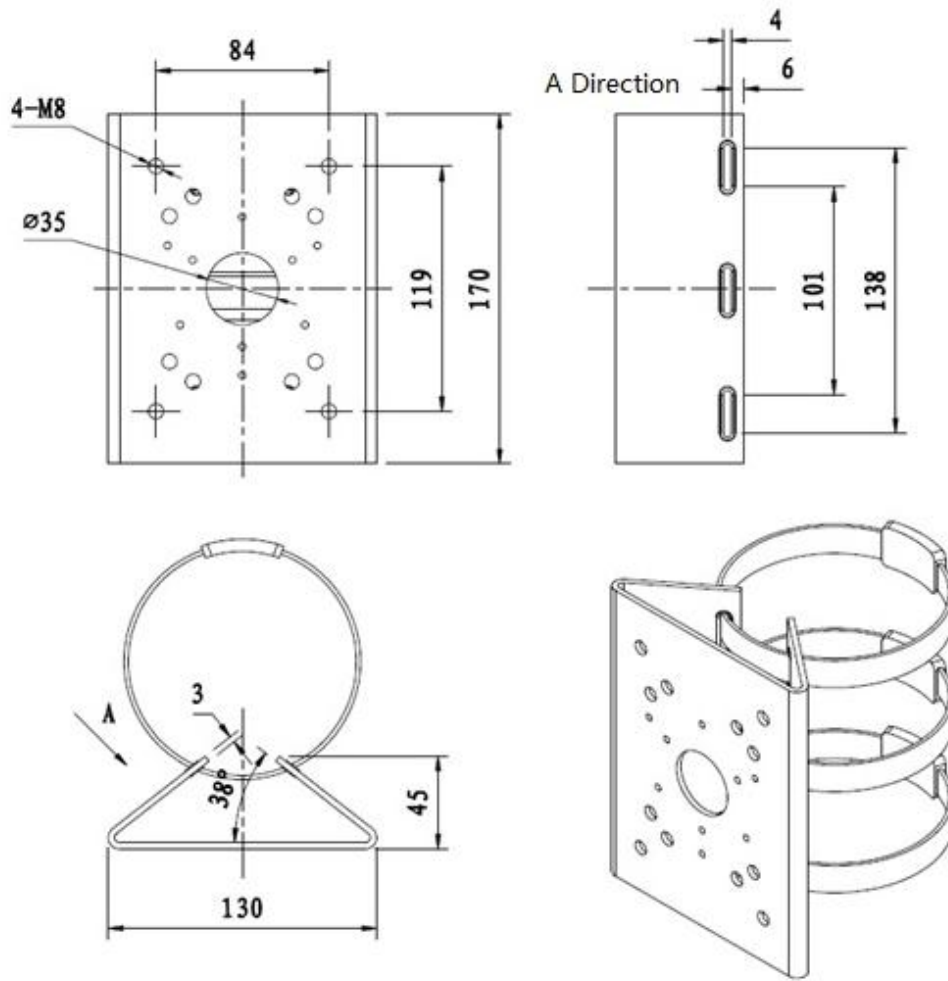

Figure 3-4

4 Wall Mount Bracket Installation

4.1 Component Installation

The wall mount bracket needs to be used with a junction box, which is shown in Figure 4-1.

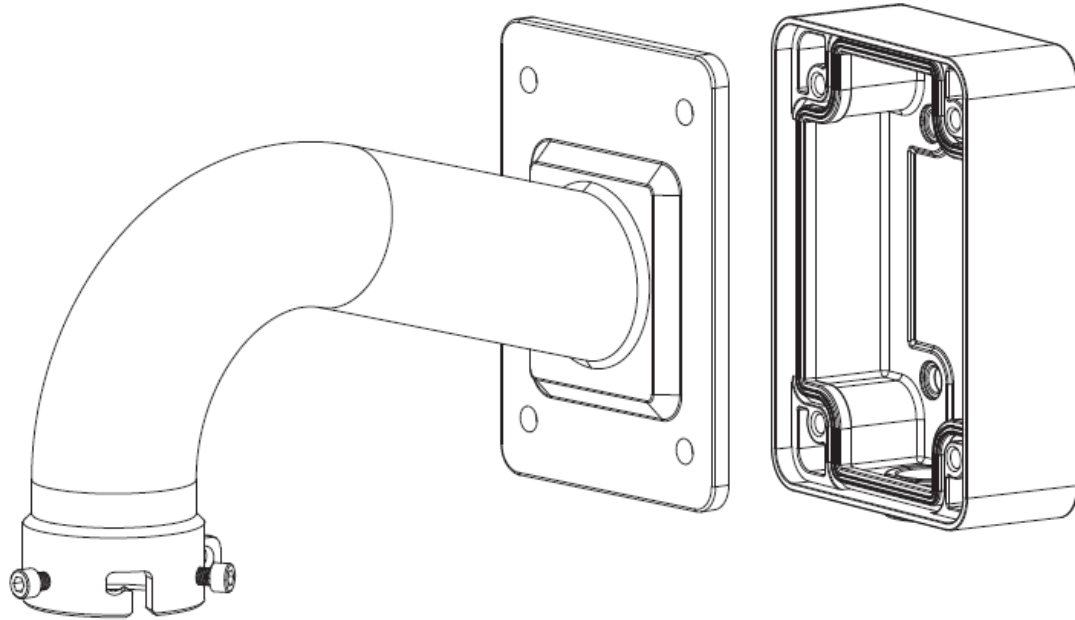

Figure 4-1

4.2 Wall Mount Installation Steps

4.2.1 Installation Requirements

The wall mount speed dome can be installed in the hard construction wall in the indoor or outdoor environments. Before the installation, please make sure:

- The wall is thick enough to install the expansion bolts.
- The wall can at least sustain the 8x weight of the speed dome, bracket and some other accessories.

4.2.2 Installation Steps

Step 1

Please draw the punch position in the wall according to the mounting holes on the bottom of the wall mount bracket. Then you can dig holes and insert the expansion bolts into the holes you just dug. Use four hex bolts and flat washer to fix the bracket in the expansion bolts. Please refer to Figure 4-2 for more details.

Note:

Take the mounting holes on the bottom of junction box as the punching template when installing the junction box.

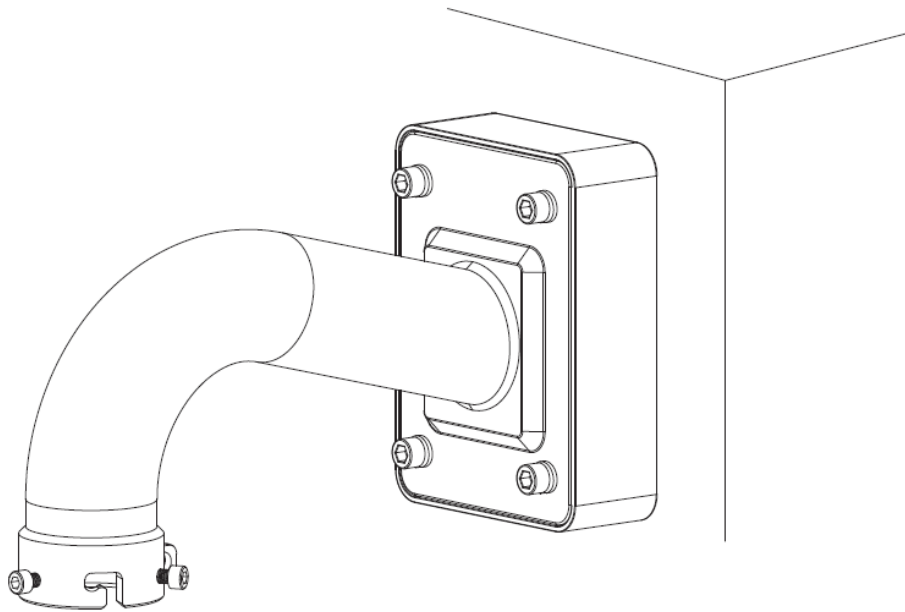

Figure 4-2

Step 2

Install the speed dome onto the wall mount bracket. Please refer to Figure 4-3 for more details. Please refer to “Chapter 2.6 Speed Dome Installation” for detailed installation modes.

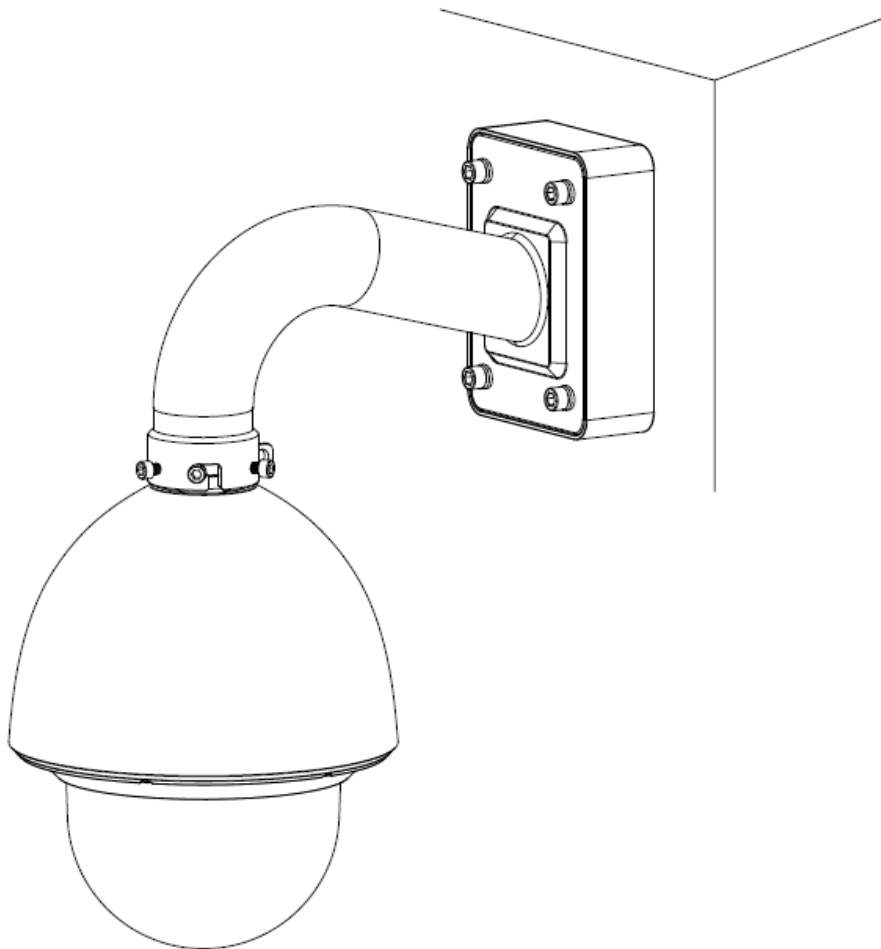

Figure 4-3

5 CORNER MOUNT BRACKET INSTALLATION

5.1 Component Installation

The corner mount bracket needs to be used with a junction box, please refer to Figure 5-1 for the accessories which are needed for installation.

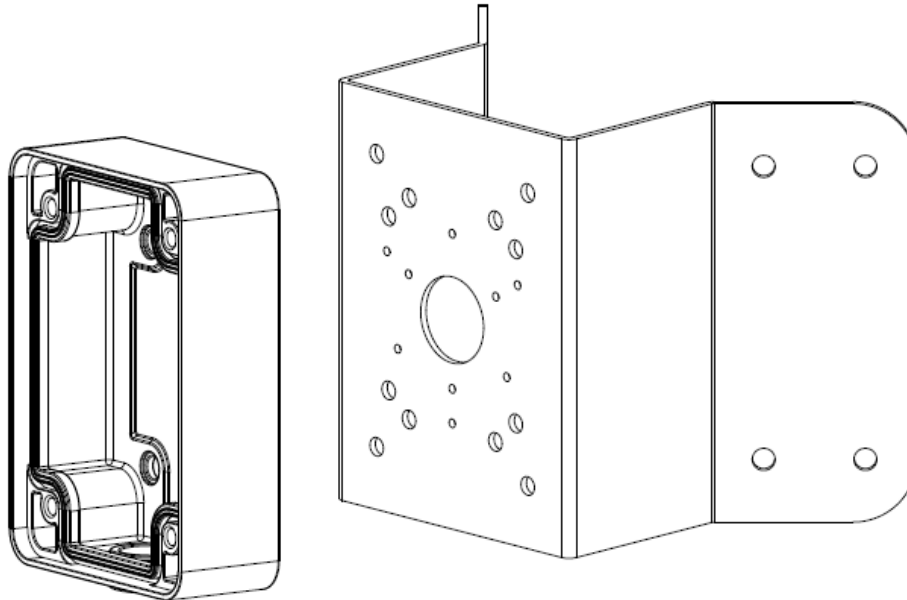

Figure 5-1

5.2 Corner Mount Bracket Installation Steps

5.2.1 Installation Requirements

The corner mount speed dome can be installed in the hard construction wall in the indoor or outdoor environments where there is a 90 ° angle. Before the installation, please make sure:

- The wall is thick enough to install the expansion bolts.
- The wall can at least sustain the 8x weight of the speed dome.

5.2.2 Installation Steps

Step 1

Please draw punching position in the wall with a 90-degree angle according to the mounting holes of the corner mount accessories. Then you can dig holes and insert M8 expansion bolts. Pull the integration cable through the center hole on the bottom of the corner mount bracket and reserve enough cable connection length and then use the M8 expansion bolts to secure the corner mount bracket chassis on the wall firmly, finally cover the outlet hole with silicon sealant to make it sealed and waterproof. Please refer to Figure 5-2 for more details.

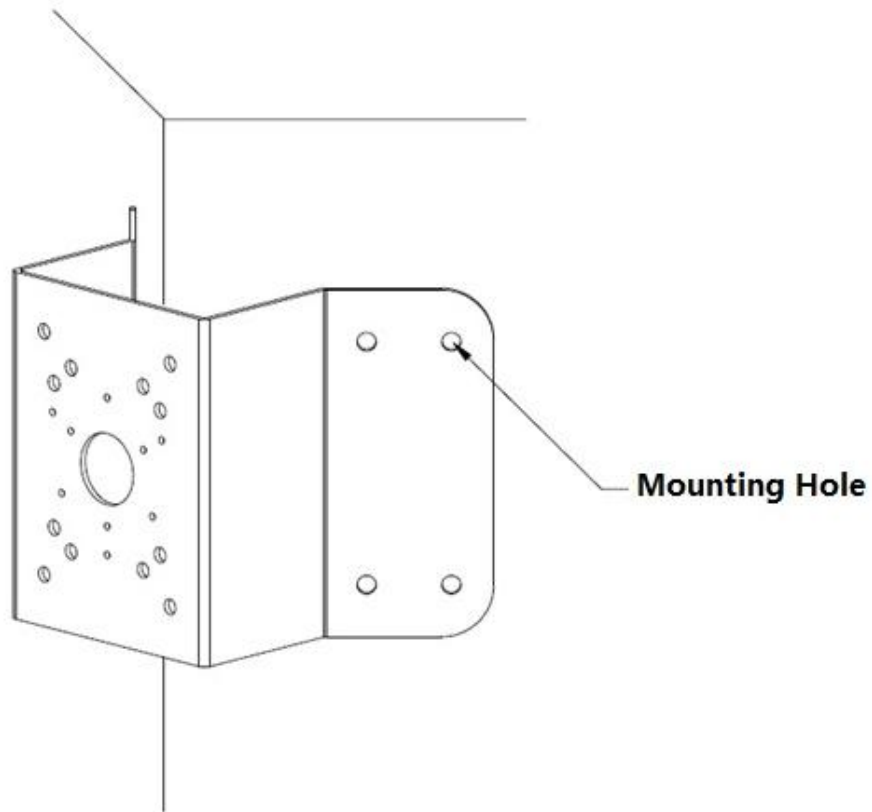

Figure 5-2

Step 2

Install a junction box on the corner mount bracket.

Step 3

Install speed dome according to Figure 5-3, please refer to Chapter 2.6 for more details about speed dome installation.

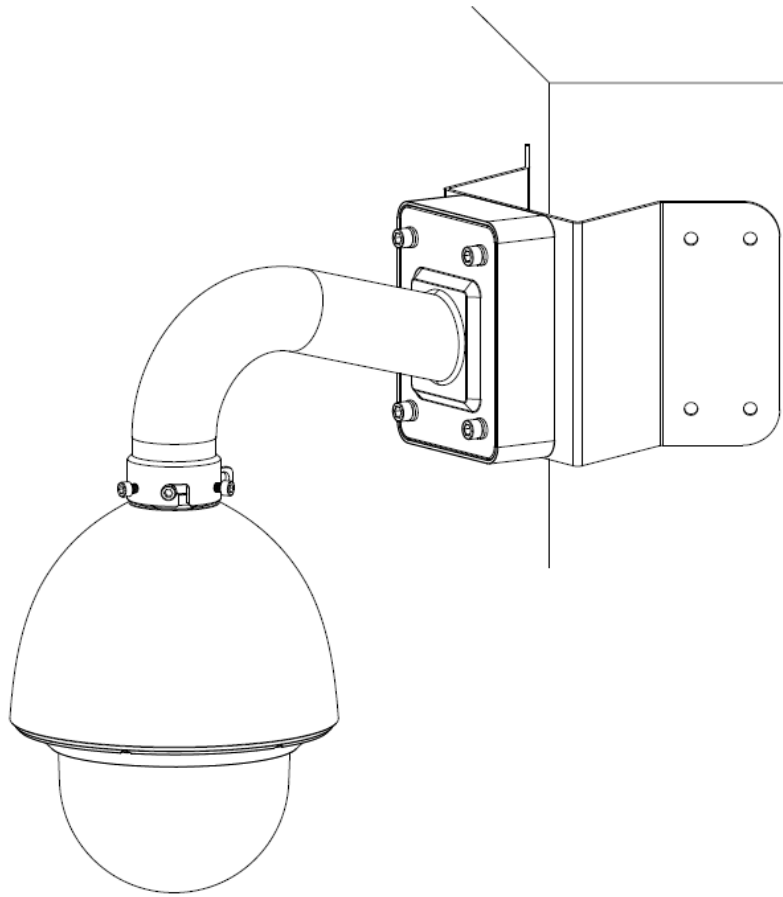

Figure 5-3

6 Pole Mount Bracket Installation

6.1 Component Installation

Pole mount bracket needs to be used with a junction box, please refer to Figure 6-1 for the accessories which are needed for installation.

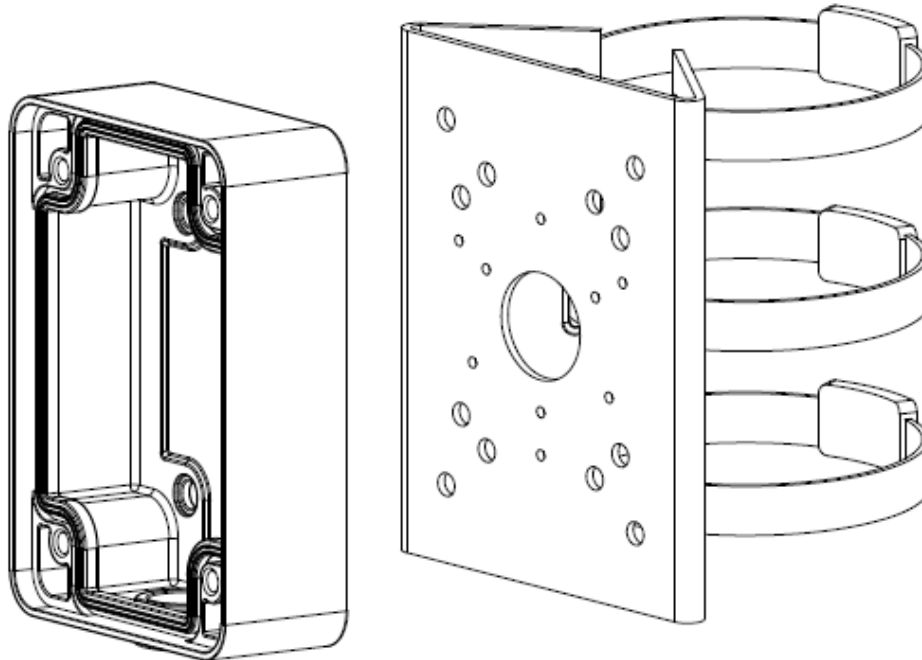

Figure 6-1

6.2 Pole Mount Bracket Installation Steps

6.2.1 Installation Requirements

The pole-mounted speed dome can be installed in the hard construction wall in the indoor or outdoor environments.

Before the installation, please make sure:

- The pole bracket can sustain the 8X weight of the speed dome.
- The diameter of the pole structure shall conform to the installation dimension of the clamp.

Default factory clamp is 5 inches for the column of $\phi 80-130\text{mm}$. It can work with the pole mount bracket. You can adjust the diameter and the value (clamp specification) is : $\phi 59-82\text{mm}$ 、 $\phi 84-108\text{mm}$ 、 $\phi 80-130\text{mm}$ 、 $\phi 130-152\text{mm}$ 、 $\phi 155-178\text{mm}$ 、 $\phi 180-203\text{mm}$ 、 $\phi 194-216\text{mm}$. It is optional according to the users' requirements, and special dimension can be customized.

6.2.2 Installation Steps

Step 1

Please refer to Figure 6-2 to install clamp and pole bracket.

Pull the cable out of the pole accessories and then use clamp to fix the pole accessories to the pole. Finally, you can use silicon sealant to cover the outlet hole to make it sealed and waterproof.

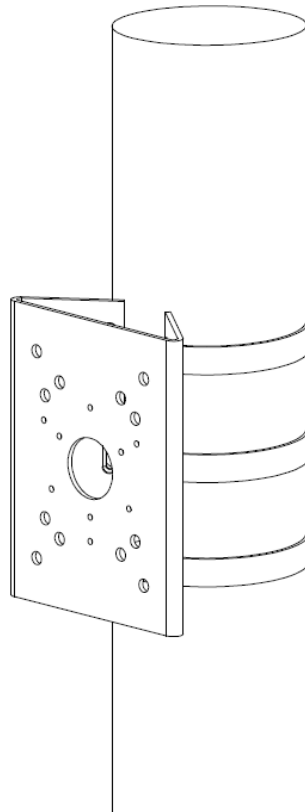

Figure 6-2

Note :

After the installation, please make sure the clamp is firmly fastened in case it may result in broken clamp.

Step 2

Install a junction box on the pole mount bracket.

Step 3

Please refer to Figure 6-3 for installation, refer to “Chapter 2.6 Speed Dome Installation” for detailed installation modes.

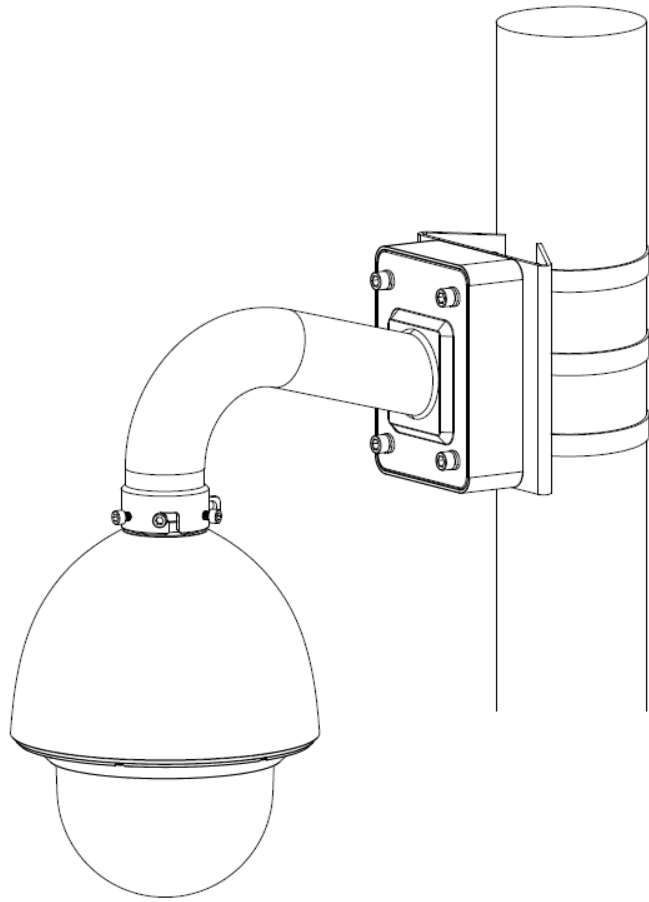

Figure 6-3

7 APPENDIX I LIGHTNING PROOF AND SURGE PROTECTION

This series speed dome adopts TVS lightning protection technology. It can effectively prevent damages from various pulse signals below 6000W, such as sudden lightning and surge. While maintaining your local electrical safety code, you still need to take necessary precaution measures when installing the speed dome in the outdoor environment.

- The distance between the signal transmission cable and high-voltage device (or high-voltage cable) shall be at least 50 meters.
- Outdoor cable layout shall go under the penthouse if possible.
- For vast land, please use sealing steel tube under the land to implement cable layout and connects one point to the earth. Open floor cable layout is forbidden.
- In area of strong thunderstorm hit or near high sensitive voltage (such as near high-voltage transformer substation), you need to install additional high-power thunder protection device or lightning rod.
- The thunder protection and earth of the outdoor device and cable shall be considered in the building whole thunder protection and conform to your local national or industry standard.
- System shall adopt equal-potential wiring. The earth device shall meet anti-jamming and at the same time conforms to your local electrical safety code. The earth device shall not short circuit to N (neutral) line of high voltage power grid or mixed with other wires. When connect the system to the earth alone, the earth resistance shall not be more than $4\ \Omega$ and earth cable cross-sectional area shall be no less than $25\ \text{mm}^2$. See Figure 7-1.

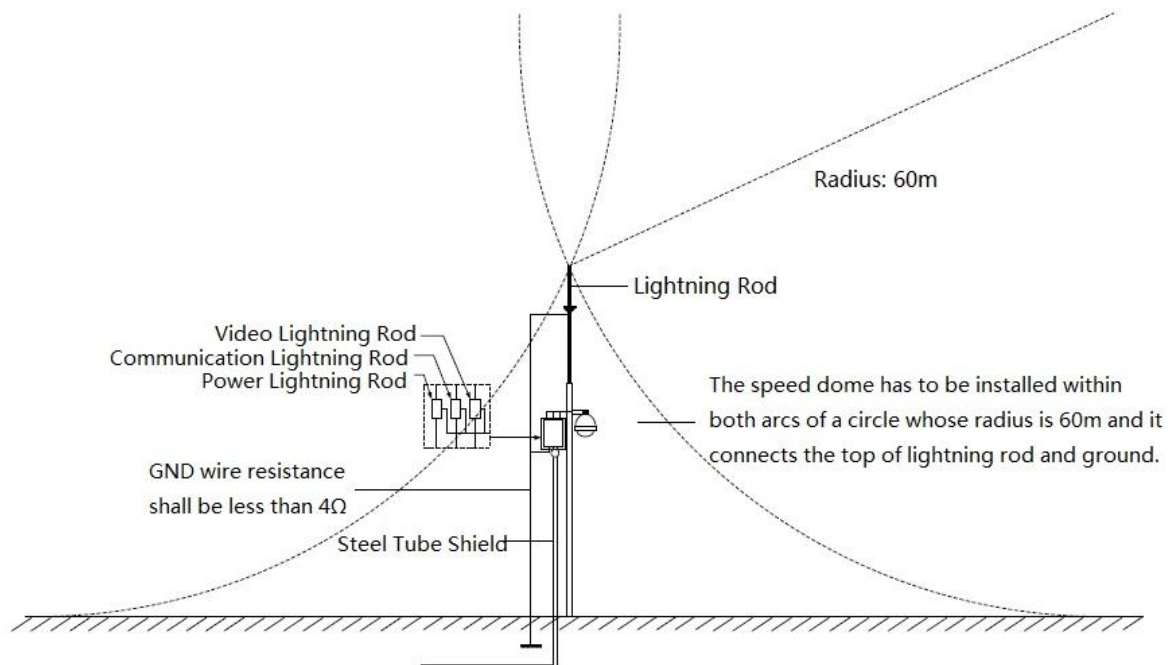

Figure 7-1

8 APPENDIX II ABOUT RS485 BUS

8.1 RS485 Bus Main Feature

RS485 is semi duplex communication cable of impedance $120\ \Omega$. Its max load amount is 32 effective loads (including main control device and devices to be charged).

8.2 RS485 Bus Transmission Distance

When we take 0.56mm (24AWG) twisted-pair as communication cable, the max transmission distance (theoretically) are listed below (according to different baud rates).

Baud Rate	Max Distance
2400 BPS	1800M
4800 BPS	1200M
9600 BPS	800M

In the following situations, the max transmission distance shall become shorter accordingly:

- The communication cable is a little bit thin;
- The surrounding environment has strong electromagnetic interference;
- There are too much devices connected to the RS485 bus;

And vice versa, the max transmission distance shall become longer.

8.3 The Problem in Practical Use

In practical usage, we usually adopt star type connection. The terminal resistance shall connect to the furthest two devices (Such as device 1# and device 15# in Figure 8-1). But this connection way does not conform to RS485 Bus standard. When the distances between devices are too long, the signal reflection occurs and anti-jamming decreases, thus the signal reliability becomes very low. You can see speed dome is not under control or speed dome is running automatically and cannot stop.

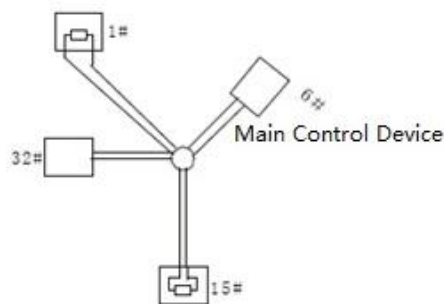

Figure 8-1

In this situation, we recommend RS485 distributor. This device can turn star type connection into the connection that conforms to RS485 bus industry standard, which can avoid the above mentioned problems and enhance communication reliability. See Figure 8-2.

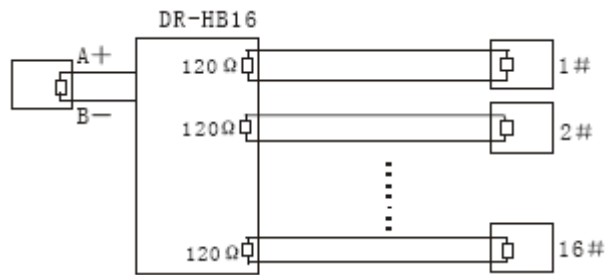

Figure 8-2

8.4 RS485 Bus FAQ

Phenomenon	Possible Reasons	Solution
Speed dome can run self-diagnosis but I cannot control it.	<ul style="list-style-type: none"> ● Host address(baud rate) and speed dome address(baud rate) are not match; ● Positive and negative end of RS485 Bus are misconnected; ● Connection cable is loose; ● RS485 Bus connection are cut off; 	<ul style="list-style-type: none"> ● Modify host or speed dome setup ; ● Switch RS485 positive end and negative end; ● Fix connection cable firmly; ● Replace RS485 Bus.
I can control the speed dome but is not smooth	<ul style="list-style-type: none"> ● RS485 Bus connection are not good; ● One RS485 bus is off; ● The distance between host and speed dome is too far; ● Parallel connected too much speed domes. 	<ul style="list-style-type: none"> ● Connect RS 485 Bus again; ● Replace RS485 Bus; ● Add terminal matching resistance; ● Add RS485 distributor.

9 APPENDIX III THE RELATIONSHIP BETWEEN THE 24V AC CABLE DIAMETER AND THE TRANSMISSION DISTANCE

It is the recommended transmission distance when the cable diameter is fixed and the 24V AC power consumption is below 10%. For the AC device, the max permission voltage power consumption is 10%. For example, when a device of rated power 20W installed from the transformer 141 inches (42m), then the min cable diameter is 0.8000mm.

Feet (m) w	mm			
	0.8000	1.000	1.250	2.000
5	488.52 (148.90)	763.31 (232.66)	1192.67 (363.53)	3053.25 (930.63)
10	244.26 (74.45)	381.66 (116.33)	596.34 (181.76)	1526.62 (465.31)
15	162.84 (49.63)	254.44 (77.55)	397.56 (121.18)	1017.75 (310.21)
20	122.13 (37.23)	190.83 (58.16)	298.17 (90.88)	763.31 (232.66)
25	97.70 (29.78)	152.66 (46.53)	238.53 (72.71)	610.65 (186.13)
30	81.42 (24.82)	127.22 (38.78)	198.78 (60.59)	508.87 (155.10)
35	69.79 (21.27)	109.04 (33.24)	170.38 (51.93)	436.18 (132.95)
40	61.06 (18.61)	95.41 (29.08)	149.08 (45.44)	381.66 (116.33)
45	54.28 (16.54)	84.81 (25.85)	132.52 (40.39)	339.25 (103.40)
50	48.85 (14.89)	76.33 (23.27)	119.27 (36.35)	305.32 (93.06)
55	44.41 (13.54)	69.39 (21.15)	108.42 (33.05)	277.57 (84.60)
60	40.71 (12.41)	63.61 (19.39)	99.39 (30.29)	254.44 (77.55)
65	37.58 (11.45)	58.72 (17.90)	91.74 (27.96)	234.87 (71.59)
70	34.89 (10.64)	54.52 (16.62)	85.19 (25.97)	218.09 (66.47)
75	32.57 (9.93)	50.89 (15.51)	79.51 (24.24)	203.55 (62.04)
80	30.53 (9.31)	47.71 (14.54)	74.54 (22.72)	190.83 (58.16)
85	28.74 (8.76)	44.90 (13.69)	70.16 (21.38)	179.60 (54.74)
90	27.14 (8.27)	42.41 (12.93)	66.26 (20.20)	169.62 (51.70)
95	25.71 (7.84)	40.17 (12.25)	62.77 (19.13)	160.70 (48.98)

Feet (m) w	mm	0.8000	1.000	1.250	2.000
100		24.43 (7.45)	38.17 (11.63)	59.63 (18.18)	152.66 (46.53)

10 APPENDIX IV THE RELATIONSHIP BETWEEN THE 12V DC CABLE DIAMETER AND THE TRANSMISSION DISTANCE

It is the recommended transmission distance when the cable diameter is fixed and the 12V DC power consumption is below 10%. For the DC device, the max permission voltage power consumption is 10%. The cables used in the following sheet are all copper wires. (the resistivity of copper is $\rho = 0.0175\Omega * \text{mm}^2/\text{m}$)

Feet (m) w	mm			
	0.8000	1.000	1.250	2.000
5	122.13 (37.23)	190.83 (58.16)	298.17 (90.88)	763.31 (232.66)
10	61.06 (18.61)	95.41 (29.08)	149.08 (45.44)	381.66 (116.33)
15	40.71 (12.41)	63.61 (19.39)	99.39 (30.29)	254.44 (77.55)
20	30.53 (9.31)	47.71 (14.54)	74.54 (22.72)	190.83 (58.16)
25	24.43 (7.45)	38.17 (11.63)	59.63 (18.18)	152.66 (46.53)
30	20.35 (6.20)	31.80 (9.69)	49.69 (15.15)	127.22 (38.78)
35	17.45 (5.32)	27.26 (8.31)	42.60 (12.98)	109.04 (33.24)
40	15.27 (4.65)	23.85 (7.27)	37.27 (11.36)	95.41 (29.08)
45	13.57 (4.14)	21.20 (6.46)	33.13 (10.10)	84.81 (28.85)
50	12.21 (3.72)	19.08 (5.82)	29.82 (9.09)	76.33 (23.27)
55	11.10 (3.38)	17.35 (5.29)	27.11 (8.26)	69.39 (21.15)
60	10.18 (3.10)	15.90 (4.85)	24.85 (7.57)	63.61 (19.39)
65	9.39 (2.86)	14.68 (4.47)	22.94 (6.99)	58.72 (17.90)
70	8.72 (2.66)	13.63 (4.15)	21.30 (6.49)	54.52 (16.62)
75	8.14 (2.48)	12.72 (3.88)	19.88 (6.06)	50.89 (15.51)
80	7.63 (2.33)	11.93 (3.64)	18.64 (5.68)	47.71 (14.54)
85	7.18 (2.19)	11.23 (3.42)	17.54 (5.35)	44.90 (13.69)
90	6.78 (2.07)	10.60 (3.23)	16.56 (5.05)	42.41 (12.93)
95	6.43 (1.96)	10.04 (3.06)	15.69 (4.78)	40.17 (12.25)

Feet (m) w	mm	0.8000	1.000	1.250	2.000
100		6.11 (1.86)	9.54 (2.91)	14.91 (4.54)	38.17 (11.63)

11 APPENDIX IV WIRE GAUGE REFERENCE SHEET

Metric bare wire diameter (mm)	AWG	SWG	Bare wire cross section (mm ²)
0.050	43	47	0.00196
0.060	42	46	0.00283
0.070	41	45	0.00385
0.080	40	44	0.00503
0.090	39	43	0.00636
0.100	38	42	0.00785
0.110	37	41	0.00950
0.130	36	39	0.01327
0.140	35		0.01539
0.160	34	37	0.02011
0.180	33		0.02545
0.200	32	35	0.03142
0.230	31		0.04115
0.250	30	33	0.04909
0.290	29	31	0.06605
0.330	28	30	0.08553
0.350	27	29	0.09621
0.400	26	28	0.1257
0.450	25		0.1602
0.560	24	24	0.2463
0.600	23	23	0.2827
0.710	22	22	0.3958
0.750	21		0.4417
0.800	20	21	0.5027
0.900	19	20	0.6362
1.000	18	19	0.7854
1.250	16	18	1.2266
1.500	15		1.7663
2.000	12	14	3.1420
2.500			4.9080
3.000			7.0683

Note

- **This manual is for reference only. Slight difference may be found in the user interface.**
- **All the designs and software here are subject to change without prior written notice.**
- **All trademarks and registered trademarks are the properties of their respective owners.**
- **If there is any uncertainty or controversy, please refer to the final explanation of us.**
- **Please visit our website or contact your local service engineer for more information.**