

6-CNF-100/150/200

100/150/200Ah Gel battery



Features

An internationally recognized green environmental protection products: rechargeable gel battery, the colloidal electrolyte is absorbed between the plates and separators, no free electrolyte in the battery:

- No need to add water during the use, maintenance free;
- No acid and sulfuric acid overflow; no pollution to the environment;
- Floating and long cycle life, low self-discharge

Technical Specifications

Model	6-CNF-100	6-CNF-150	6-CNF-200
Rated voltage	12Vdc		
Capacity(25°C, 120hr)	120Ah	180Ah	240Ah
Capacity(25°C, 20hr)	105Ah	158Ah	210Ah
Capacity(25°C, 10hr)	100Ah	150Ah	200Ah
Capacity(25°C, 3hr)	75Ah	112.5Ah	150Ah
Discharge temperature range	-20°C~+60°C(-4°F ~+140°F)		
Charge temperature range	-10°C~+60°C(14°F ~+140°F)		
Storage temperature range	-20°C~+60°C(-4°F ~+140°F)		
Max. charging current	30A(0.3C)	45A(0.3C)	60A (0.3C)
Max. discharge current	900A(5S)	1370A(5S)	1800A(5S)
Resistance	5Ω (be a fully charged state at 25°C)		
Self-discharge	The average monthly capacity will drop by 4% at 20°C		
Connection type	M8 terminal & lead-out wire		
Dimension	370mmx172mmx220mm (14.57"x6.77"x8.66")	485mmx172mmx240mm (19.09"x6.77"x9.45")	520mmx240mmx220mm (20.47"x9.45"x8.66")
Weight	28kg(61.73lb)	42kg(92.59lb)	57kg(125.66lb)

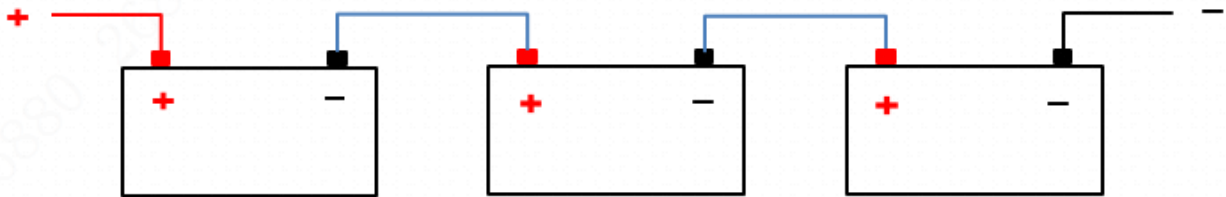

Series connection

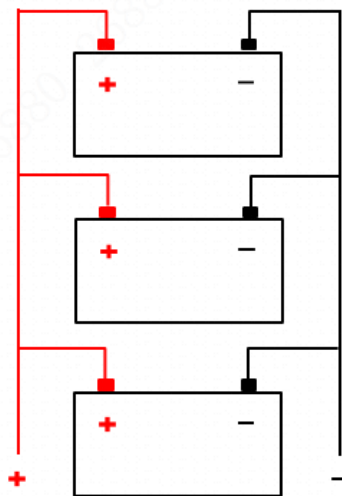

Parallel connection

Order Information

Product	Part Number	Description
Power series	6-CNY-100	100Ah Gel battery
	6-CNY-150	150Ah Gel battery
	6-CNY-200	200Ah Gel battery

Application



Package Information

- 100/150/200Ah gel battery 6-CNF-100/150/200 *1